

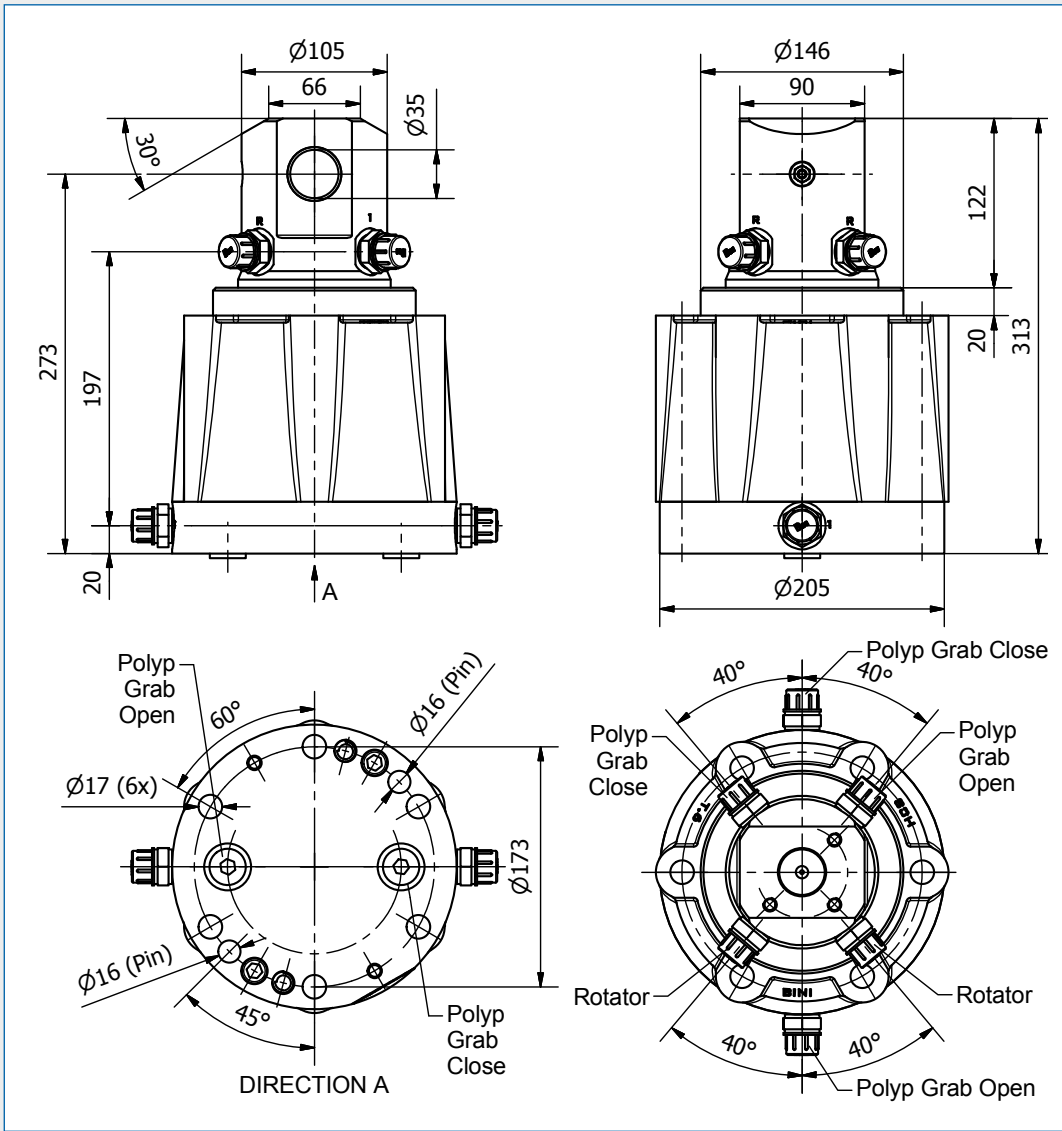





T.6 pist. 360°



 Rotazione Continua	 Rotation Unlimited	 Rotation Continue	 Drehen Unbegrenzt	 Вращение Постоянное	 Rotación Continua	
Carico assiale statico	Static Axial Load	Charge axiale statique	Traglast axial statisch	Статическая грузоподъёмность	Carga axial estática	60 kN - 60 кН (13488 lbf)
Carico assiale dinamico	Dynamic Axial Load	Charge axiale dynamique	Traglast axial dynamisch	Динамическая грузоподъёмность	Carga axial dinámica	30 kN - 30 кН (6744 lbf)
Coppia/180 bar	Torque/180 bar (2610 psi)	Couple/180 bar	Drehmoment/180 bar	Вращающий момент/180 бар	Par de rotación/180 bar	680 Nm(Нм) - (501 lbf ft)
Cilindrata	Displacement	Cylindrée	Hubraum	Объём	Cilindrada	300 cm ³
Peso	Weight	Poids	Gewicht	Масса	Peso	49 Kg. (кр.) - (108 lb)
Pressione d'esercizio max.	Max. working pressure	Pression de travail maxi.	Betriebsdruck max.	Давление рабочей жидкости при вращении (макс.)	Presión de trabajo max.	220 bar (2206ap)
Pressione polipo	Grab pressure	Pression grappin	Druck Polyogreifer	Давление многочелюстного грейфера	Presión Pulpo	300 bar (3006ap)
RACCORDI	COUPLINGS	RACCORDS	ANSCHLÜSSE	ПРИСОЕДИНИТЕЛЬНЫЕ РАЗМЕРЫ	EMPALMES	
R = Rotazione	R = Rotation	R = Rotation	R = Drehen	R = Вращение	R = Rotación	G 1/2
GO - GC = Benna a polipo	GO - GC = Polyp Grapple	GO - GC = Grappin pour reprise de bois	GO - GC = Mehrschalengreifer	GO - GC = Грейферный	GO - GC = Pulpos hidraulicos	G 1/2